

# WLP3000 GREASE INTERCEPTOR TANK SPECIFICATIONS

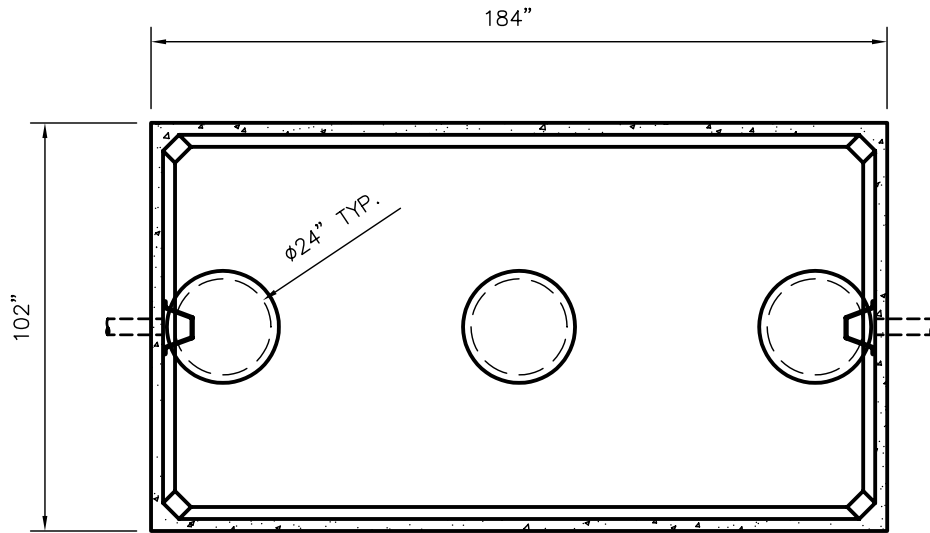

TOP VIEW

**DIMENSIONS:**

- WALL: 3"
- BOTTOM: 3"
- COVER: 6"
- MANHOLE: 24" I.D. PRECAST CONCRETE RISER
- HEIGHT: 60 3/4" O.D.
- LENGTH: 184" O.D.
- WIDTH: 102" O.D.
- BELOW INLET: 48" O.D.
- LIQUID LEVEL: 43"
- WEIGHT: 3" BOTTOM 13,013 LBS.
- WEIGHT: COVER 9,300 LBS.

**INLET AND OUTLET:**

- 4" CAST-A-SEAL BOOT OR EQUAL
- GASKET, CAST-A-SEAL BOOT OR EQUAL

**INLET AND OUTLET BAFFLE:**  
AS SHOWN

LIQUID CAPACITY: 69.77 GAL/IN

LOADING DESIGN: 8' 0" UNSATURATED SOIL

TANK CAN BE USED AS:  
GREASE INTERCEPTOR

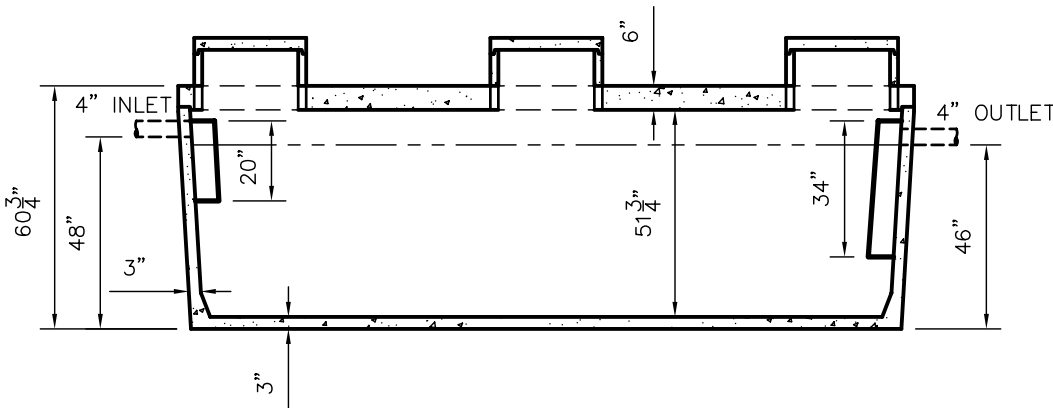

SIDE VIEW

CUSTOMIZED TANKS:  
TANKS CAN BE CUSTOMIZED CONTACT WIESER CONCRETE  
TANKS ARE MANUFACTURED TO MEET OR EXCEED ASTM C-1227 REQUIREMENTS

SCALE: 1/4" = 1'	REV NO.	DATE:	
DRAWN BY: SWT			
DATE: JANUARY 2008			
FILE: WLP3000GI			
<b>WIESER CONCRETE</b>			
W3716 US HWY10. MAIDEN ROCK, WI 54750			
800-325-8456			
WLP3000GI	SEPTIC MANUAL		
	REV. JAN. 2008		
SHEET NO.			
0	OF		
0			