

WLP2500 GREASE INTERCEPTOR TANK SPECIFICATIONS

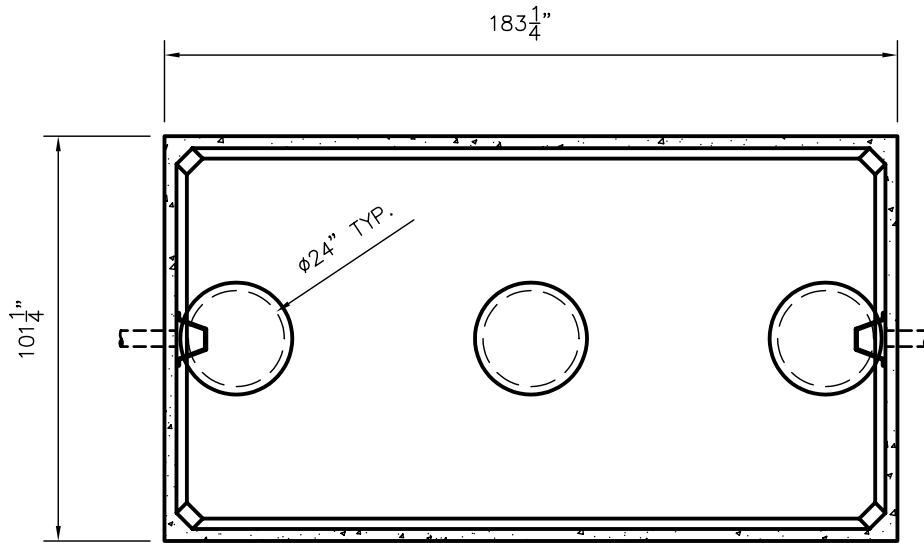

TOP VIEW

DIMENSIONS:

- WALL: 3"
- BOTTOM: 3"
- COVER: 6"
- MANHOLE: 24" I.D. PRECAST CONCRETE RISER
- HEIGHT: 53 3/4" O.D.
- LENGTH: 183 1/4" O.D.
- WIDTH: 101 1/4" O.D.
- BELOW INLET: 41" O.D.
- LIQUID LEVEL: 36"
- WEIGHT: 3" BOTTOM 12,560 LBS.
- WEIGHT: COVER 9,300 LBS.

INLET AND OUTLET:

- 4" CAST-A-SEAL BOOT OR EQUAL
- GASKET, CAST-A-SEAL BOOT OR EQUAL

INLET AND OUTLET BAFFLE:
AS SHOWN

LIQUID CAPACITY: 69.44 GAL/IN

LOADING DESIGN: 8' 0" UNSATURATED SOIL

TANK CAN BE USED AS:

GREASE INTERCEPTOR

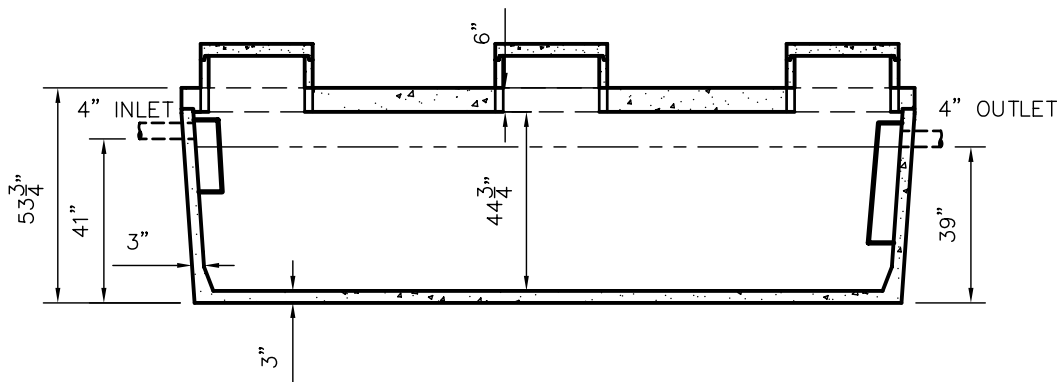

SIDE VIEW

CUSTOMIZED TANKS:

TANKS CAN BE CUSTOMIZED CONTACT WIESER CONCRETE

TANKS ARE MANUFACTURED TO MEET OR EXCEED ASTM C-1227 REQUIREMENTS

SCALE: 1/4" = 1'	REV NO.	DATE:	
DRAWN BY: SWT			
DATE: JANUARY 2008			
FILE: WLP2500GI			
WIESER CONCRETE			
W3716 US HWY10. MAIDEN ROCK, WI 54750			
800-325-8456			
WLP2500GI	SEPTIC MANUAL		
	REV. JAN. 2008		
SHEET NO.			
0	OF		
/			
0			