

# WLP2000-P TANK SPECIFICATIONS

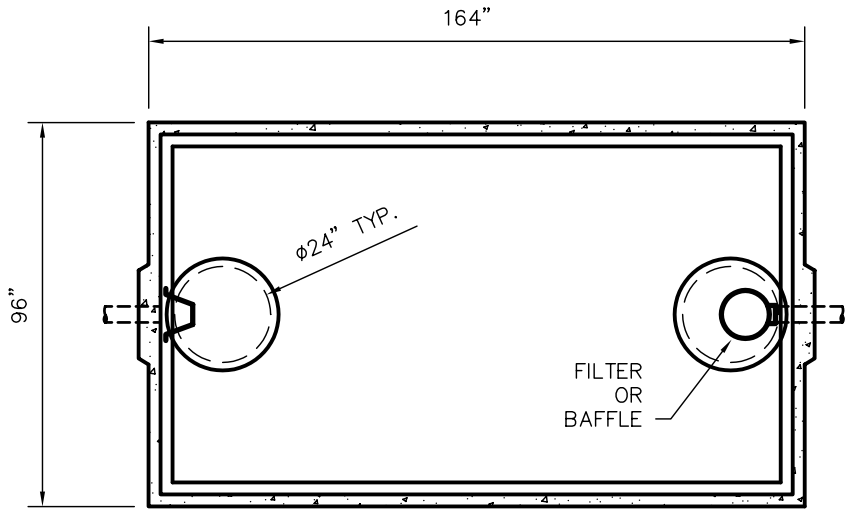

TOP VIEW

**DIMENSIONS:**  
 WALL: 3"  
 BOTTOM: 3" SEPTIC/HOLDING  
           5" HEAVY DUTY HOLDING (ADD 2,800 LBS.)  
 COVER: 6"  
 MANHOLE: 24" I.D. PRECAST CONCRETE RISER  
 HEIGHT: 53" O.D.  
 LENGTH: 164" O.D.  
 WIDTH: 96" O.D.  
 BELOW INLET: 41" O.D.  
 LIQUID LEVEL: 36"  
 WEIGHT: 21,120 LBS.

**INLET AND OUTLET:**  
 4" CAST-A-SEAL BOOT OR EQUAL  
 GASKET, CAST-A-SEAL BOOT OR EQUAL  
**INLET AND OUTLET Baffle AND FILTER:**  
 WISCONSIN, SEE DETAIL #10

LIQUID CAPACITY: 56.27 GAL/IN

LOADING DESIGN: 8' 0" UNSATURATED SOIL

**HOLDING TANK:**  
 OUTLET HOLE PLUGGED  
 ACTUAL CAPACITY: 2,138 GALLONS

TANK CAN BE USED AS:  
 SEPTIC/ HOLDING/ PUMP OR SIPHON

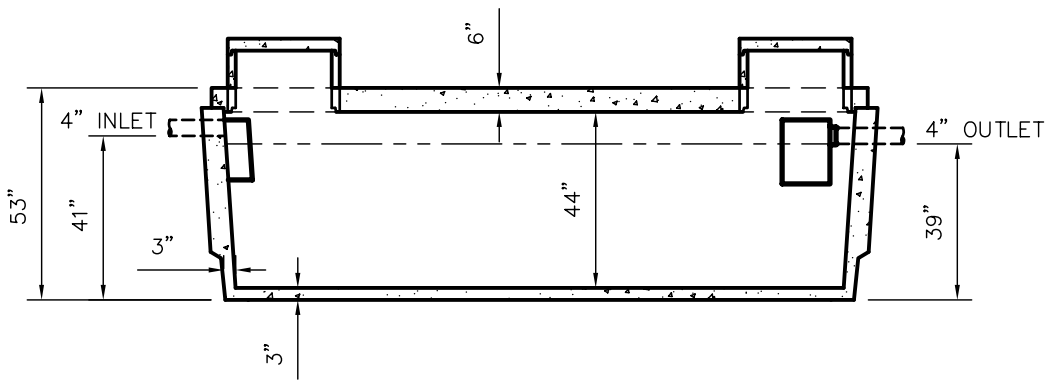

SIDE VIEW

CUSTOMIZED TANKS:  
 TANKS CAN BE CUSTOMIZED CONTACT WIESER CONCRETE  
 TANKS ARE MANUFACTURED TO MEET OR EXCEED ASTM C-1227 REQUIREMENTS

SCALE: 1/4" = 1'	REV NO.	DATE:	
DRAWN BY: SWT	REV NO.	DATE:	FILE: WLP2000-P
DATE: JANUARY 2008	<b>WIESER CONCRETE</b>		
W3716 US HWY10, MAIDEN ROCK, WI 54750			
800-325-8456			
WLP2000-P	SEPTIC MANUAL		
REV. JAN. 2008			
SHEET NO.		OF	
0		0	