

# W850-P TANK SPECIFICATIONS

DIMENSIONS:  
 WALL: 2 1/2"  
 BOTTOM: 2 1/2"  
 COVER: 4"  
 MANHOLE: 24" I.D. PRECAST CONCRETE RISER  
 HEIGHT: 57" O.D.  
 LENGTH: 102" O.D.  
 WIDTH: 67" O.D.  
 BELOW INLET: 46 1/2" O.D.  
 LIQUID LEVEL: 42"  
 WEIGHT: 6,609 LBS.

INLET AND OUTLET:  
 4" CAST-A-SEAL BOOT OR EQUAL  
 GASKET, CAST-A-SEAL BOOT OR EQUAL  
 INLET AND OUTLET Baffle AND FILTER:  
 WISCONSIN, SEE DETAIL #10

LIQUID CAPACITY: 21.00 GAL/IN

LOADING DESIGN: 8' 0" UNSATURATED SOIL

HOLDING TANK:  
 OUTLET HOLE PLUGGED  
 ACTUAL CAPACITY: 912 GALLONS

TANK CAN BE USED AS:  
 SEPTIC/ HOLDING/ PUMP OR SIPHON

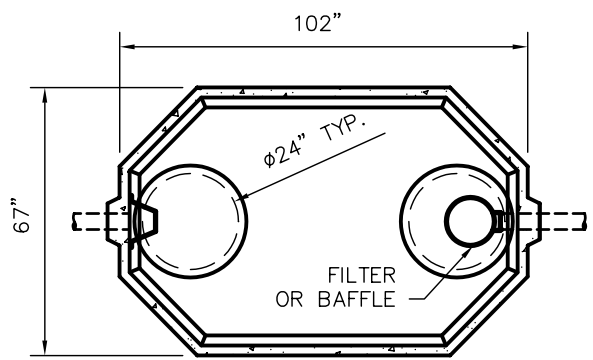

TOP VIEW

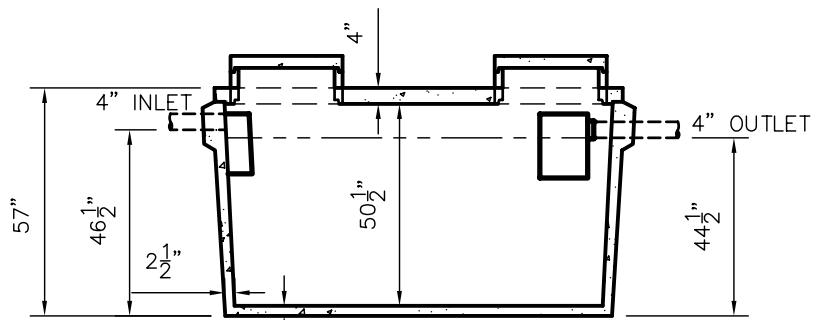

SIDE VIEW

CUSTOMIZED TANKS:  
 TANKS CAN BE CUSTOMIZED CONTACT WIESER CONCRETE  
 TANKS ARE MANUFACTURED TO MEET OR EXCEED ASTM C-1227 REQUIREMENTS

SCALE: 1/4" = 1'	REV NO.	DATE:	
DRAWN BY: SWT			
DATE: JANUARY 2008			
FILE: W850-P			
<b>WIESER CONCRETE</b>			
W3716 US HWY10, MAIDEN ROCK, WI 54750			
800-325-8456			
W850-P	SEPTIC MANUAL		
REV. JAN. 2008			
SHEET NO.			
0 OF 0			