

W1000-P TANK SPECIFICATIONS

DIMENSIONS:
 WALL: 2 1/2"
 BOTTOM: 2 1/2"
 COVER: 4"
 MANHOLE: 24" I.D. PRECAST CONCRETE RISER
 HEIGHT: 57 1/2" O.D.
 LENGTH: 121" O.D.
 WIDTH: 67" O.D.
 BELOW INLET: 46 1/2" O.D.
 LIQUID LEVEL: 42"
 WEIGHT: 8,700 LBS.

INLET AND OUTLET:
 4" CAST-A-SEAL BOOT OR EQUAL
 GASKET, CAST-A-SEAL BOOT OR EQUAL
 INLET AND OUTLET BAFFLE AND FILTER:
 WISCONSIN, SEE DETAIL #10

LIQUID CAPACITY: 26.00 GAL/IN

LOADING DESIGN: 8' 0" UNSATURATED SOIL

HOLDING TANK:
 OUTLET HOLE PLUGGED
 ACTUAL CAPACITY: 1,153 GALLONS

TANK CAN BE USED AS:
 SEPTIC/ HOLDING/ PUMP OR SIPHON

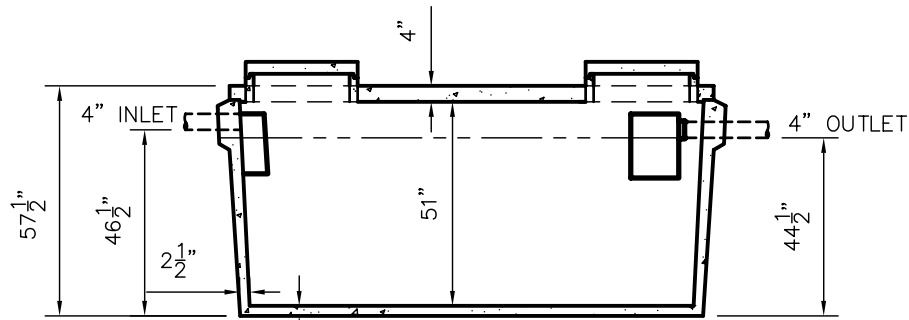
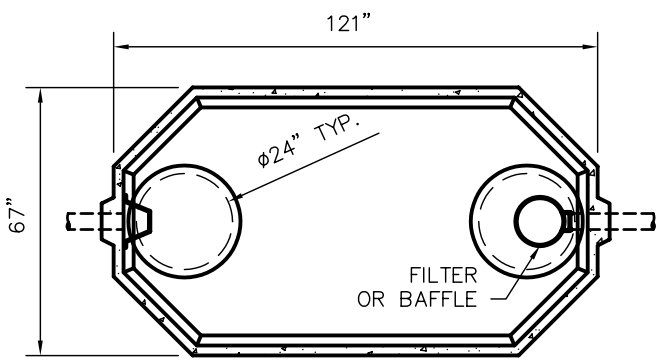

CUSTOMIZED TANKS:
 TANKS CAN BE CUSTOMIZED CONTACT WIESER CONCRETE
 TANKS ARE MANUFACTURED TO MEET OR EXCEED ASTM C-1227 REQUIREMENTS

SCALE: 1/4" = 1'	REV NO.	DATE:	
DRAWN BY: SWT			
DATE: JANUARY 2008			
FILE: W1000-P			
WIESER CONCRETE			
W3716 US HWY10, MAIDEN ROCK, WI 54750			
800-325-8456			
W1000-P	SEPTIC MANUAL		
	REV. JAN. 2008		
SHEET NO.	0 OF 0		