

# WLP1000 600-P TANK SPECIFICATIONS

**DIMENSIONS:**

WALL: 3"  
 BOTTOM: 3"  
 COVER: 6"  
 MANHOLE: 24" I.D. PRECAST CONCRETE RISER  
 HEIGHT: 53" O.D.  
 LENGTH: 155 1/2" O.D.  
 WIDTH: 81 5/8" O.D.  
 BELOW INLET: 41" O.D.  
 LIQUID LEVEL: 36"  
 WEIGHT: 17,200 LBS.

**INLET AND OUTLET:**  
 4" CAST-A-SEAL BOOT OR EQUAL  
 GASKET, CAST-A-SEAL BOOT OR EQUAL  
**INLET AND OUTLET BAFFLE AND FILTER:**  
 WISCONSIN, SEE DETAIL #10

**LIQUID CAPACITY:** 27.88 GAL/IN (SEPTIC)  
 16.83 GAL/IN (PUMP)

**LOADING DESIGN:** 8' 0" UNSATURATED SOIL

TANK CAN BE USED AS:  
 SEPTIC/SEPTIC, SEPTIC/PUMP  
 OR SEPTIC/SIPHON

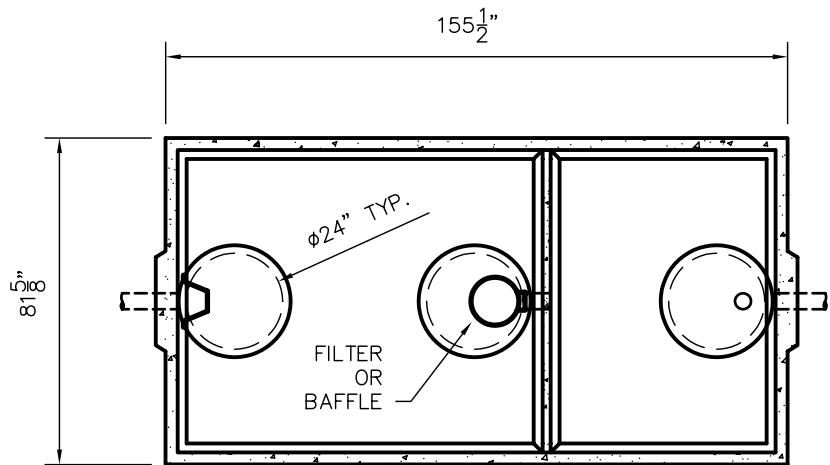

TOP VIEW

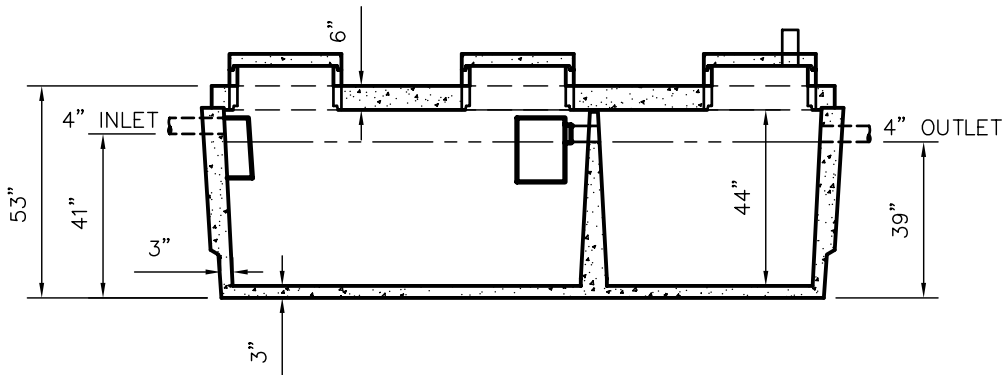

SIDE VIEW

**CUSTOMIZED TANKS:**  
 TANKS CAN BE CUSTOMIZED CONTACT WIESER CONCRETE  
 TANKS ARE MANUFACTURED TO MEET OR EXCEED ASTM C-1227 REQUIREMENTS

SCALE: 1/4" = 1'	REV NO.	DATE:
DRAWN BY: SWT		
DATE: JANUARY 2008		
FILE: WLP1000/600-P		
<b>WIESER CONCRETE</b>		
W3716 US HWY10, MAIDEN ROCK, WI 54750		
800-325-8456		
WLP1000/600-P	SEPTIC MANUAL	
	REV. JAN. 2008	
SHEET NO.	0 OF 0	