

W1450 950-P TANK SPECIFICATIONS

DIMENSIONS:

- WALL: 3"
- BOTTOM: 3"
- COVER: 5"
- MANHOLE: 24" I.D. PRECAST CONCRETE RISER
- HEIGHT: 76" O.D.
- LENGTH: 145 3/8" O.D.
- WIDTH: 79 1/4" O.D.
- BELOW INLET: 65" O.D.
- LIQUID LEVEL: 60"
- WEIGHT: 20,095 LBS.

INLET AND OUTLET:
 4" CAST-A-SEAL BOOT OR EQUAL
 GASKET, CAST-A-SEAL BOOT OR EQUAL
INLET AND OUTLET BAFFLE AND FILTER:
 WISCONSIN, SEE DETAIL #10

LIQUID CAPACITY: 24.91 GAL/IN (SEPTIC)
 16.20 GAL/IN (PUMP)

LOADING DESIGN: 8' 0" UNSATURATED SOIL

TANK CAN BE USED AS:
 SEPTIC/SEPTIC, SEPTIC/PUMP
 OR SEPTIC/SIPHON

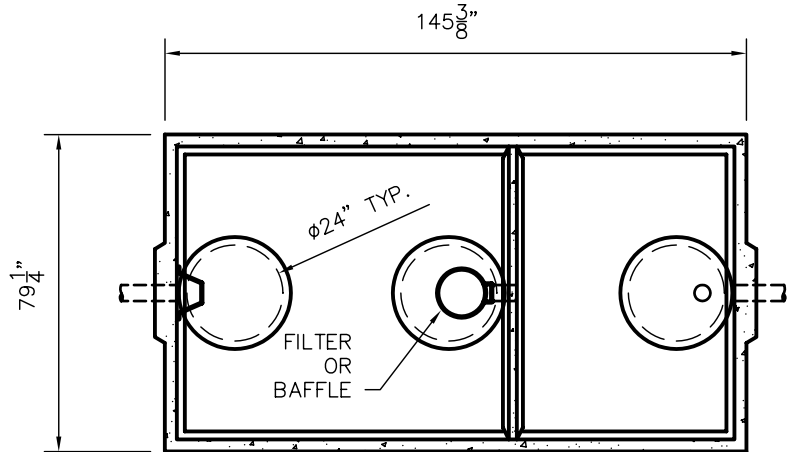

TOP VIEW

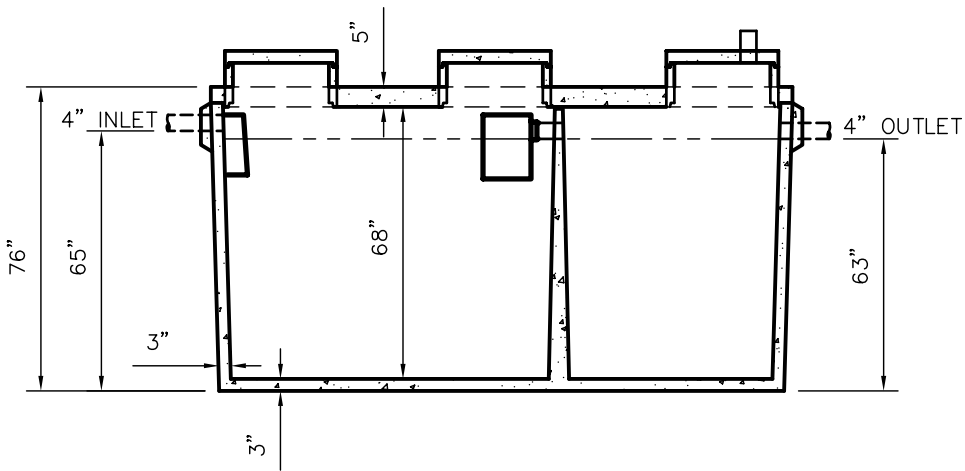

SIDE VIEW

CUSTOMIZED TANKS:
 TANKS CAN BE CUSTOMIZED CONTACT WIESER CONCRETE
 TANKS ARE MANUFACTURED TO MEET OR EXCEED ASTM C-1227 REQUIREMENTS

| | | |
|---------------------------------------|---------------|-------|
| SCALE: 1/4" = 1' | REV NO. | DATE: |
| DRAWN BY: SWT | | |
| DATE: JANUARY 2008 | | |
| FILE: W1450/950-P | | |
| WIESER CONCRETE | | |
| W3716 US HWY10, MAIDEN ROCK, WI 54750 | | |
| 800-325-8456 | | |
| W1450/950-P | SEPTIC MANUAL | |
| REV. JAN. 2008 | | |
| SHEET NO. | | |
| 0 | OF | |
| 0 | | |