

WLP750-MR TANK SPECIFICATIONS

DIMENSIONS:

WALL: 2 1/2"
 BOTTOM: 3"
 COVER: 4"
 MANHOLE: 24" I.D. PRECAST CONCRETE RISER
 HEIGHT: DOME COVER 61" O.D.
 FLAT COVER 53 1/4" O.D.
 OUTSIDE DIAMETER: 84" O.D.
 BELOW INLET: 42" O.D.
 LIQUID LEVEL: 37"
 WEIGHT: 6,150 LBS.

INLET AND OUTLET:

4" CAST-A-SEAL BOOT OR EQUAL
 GASKET, CAST-A-SEAL BOOT OR EQUAL

INLET AND OUTLET BAFFLE AND FILTER:

WISCONSIN, SEE DETAIL #10
 (OTHER STATES SEE CHART)

LIQUID CAPACITY: 20.28 GAL/IN

HOLDING TANK:

ACTUAL CAPACITY: 790 GALLONS
 OUTLET HOLE PLUGGED

LOADING DESIGN: 8' 0" UNSATURATED SOIL

MN TANKS:

WILL HAVE ONE VENT OVER OUTLET
 AND WILL HAVE TWO VENTS IN COVER OVER INLET

TANK CAN BE USED AS:

SEPTIC/ HOLDING/ PUMP OR SIPHON

CUSTOMIZED TANKS:

TANKS CAN BE CUSTOMIZED CONTACT WIESER CONCRETE

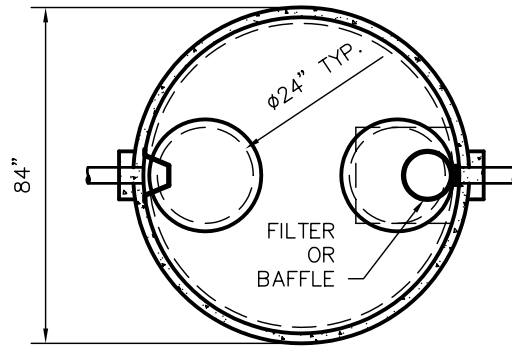

TOP VIEW

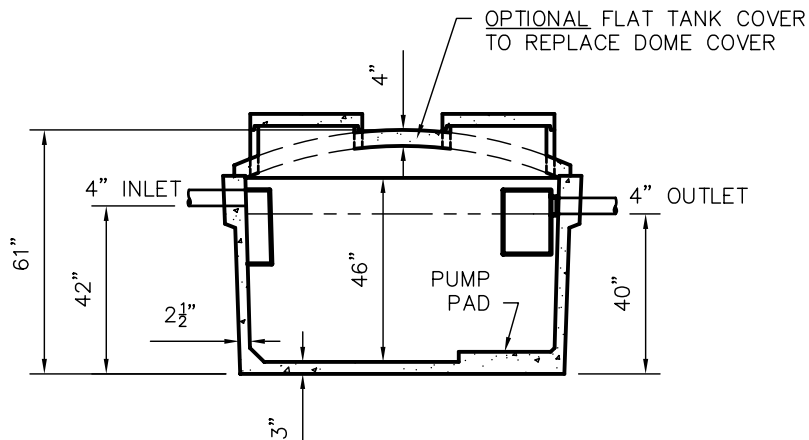

SIDE VIEW

SCALE: 1/4" = 1'	REV NO.	DATE:	
DRAWN BY: SWT			
DATE: JANUARY 2008			
FILE: WLP750-MR			
WIESER CONCRETE			
W3716 US HWY10, MAIDEN ROCK, WI 54750			
800-325-8456			
WLP750-MR	SEPTIC MANUAL		
	REV. JAN. 2008		
SHEET NO.			
0	OF		
/	0		

TANKS ARE MANUFACTURED TO MEET OR EXCEED ASTM C-1227 REQUIREMENTS