

WLP1250-MR TANK SPECIFICATIONS

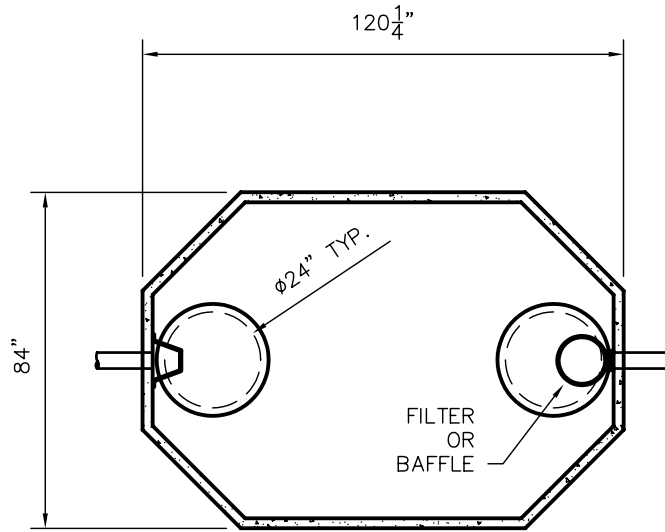

TOP VIEW

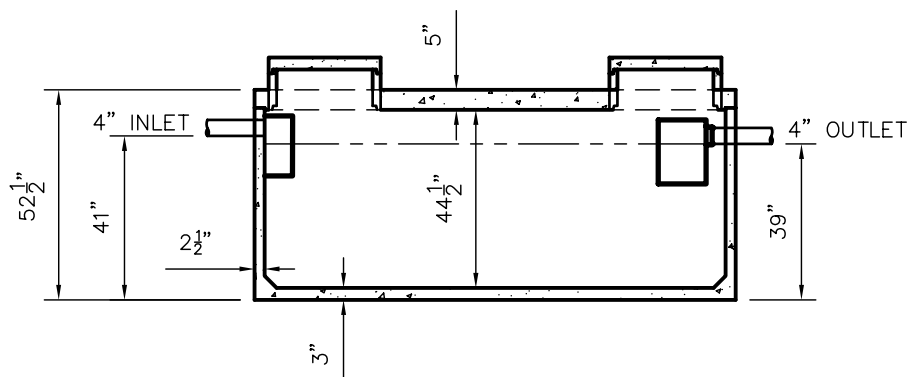

SIDE VIEW

DIMENSIONS:
 WALL: 2 1/2"
 BOTTOM: SEPTIC 3"
 COVER: 5"
 MANHOLE: 24" I.D. PRECAST CONCRETE RISER
 HEIGHT: 52 1/2" O.D.
 LENGTH: 120 1/4" O.D.
 WIDTH: 84" O.D.
 BELOW INLET: 41" O.D.
 LIQUID LEVEL: 36"
 WEIGHT: 8,810 LBS.

INLET AND OUTLET:
 4" CAST-A-SEAL BOOT OR EQUAL
 GASKET, CAST-A-SEAL BOOT OR EQUAL

INLET AND OUTLET BAFFLE AND FILTER:
 WISCONSIN, SEE DETAIL #10
 (OTHER STATES SEE CHART)

LIQUID CAPACITY: 34.81 GAL/IN

HOLDING TANK:
 OUTLET HOLE PLUGGED
 ACTUAL CAPACITY: 1,253 GALLONS

LOADING DESIGN: 8' 0" UNSATURATED SOIL

MN TANKS:
 WILL HAVE ONE VENT OVER OUTLET
 AND WILL HAVE TWO VENTS IN COVER OVER INLET

TANK CAN BE USED AS:
 SEPTIC/ HOLDING/ PUMP OR SIPHON

CUSTOMIZED TANKS:
 TANKS CAN BE CUSTOMIZED CONTACT WIESER CONCRETE

SCALE: 1/4" = 1'	REV NO.	DATE:	
DRAWN BY: SWT			
DATE: JANUARY 2008			
FILE: WLP1250-MR			
WIESER CONCRETE			
W3716 US HWY10, MAIDEN ROCK, WI 54750			
800-325-8456			
WLP1250-MR	SEPTIC MANUAL		
	REV. JAN. 2008		
SHEET NO.			
0 OF 0			

TANKS ARE MANUFACTURED TO MEET OR EXCEED ASTM C-1227 REQUIREMENTS