

W1250-MR TANK SPECIFICATIONS

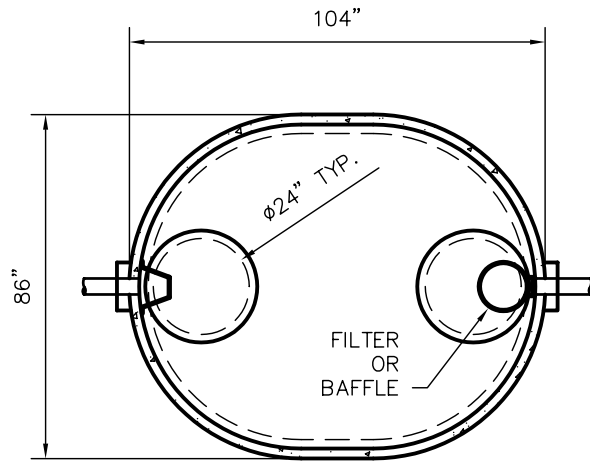

TOP VIEW

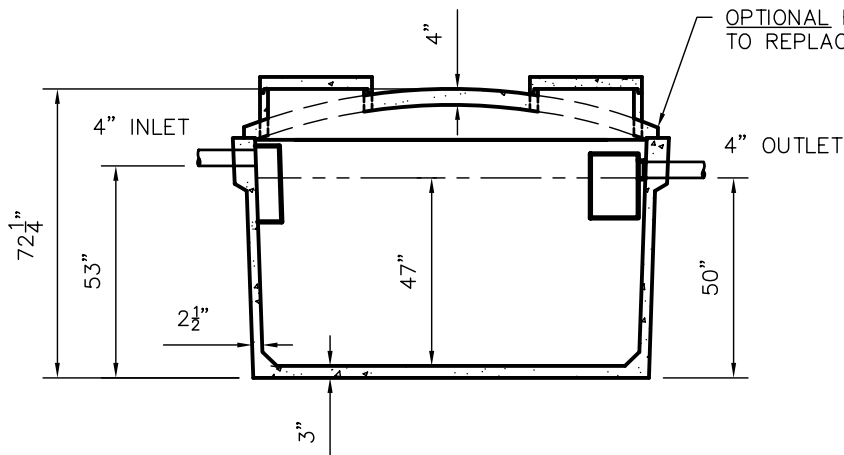

SIDE VIEW

DIMENSIONS:

- WALL: 2 1/2"
- BOTTOM: SEPTIC 3"
HOLDING 5" (ADD 1300 LB.)
- COVER: 4"
- MANHOLE: 24" I.D. PRECAST CONCRETE RISER
- HEIGHT: 72" O.D.
- LENGTH: 104" O.D.
- WIDTH: 86" O.D.
- BELOW INLET: 53" O.D.
- LIQUID LEVEL: 47"
- WEIGHT: 7,220 LBS.

INLET AND OUTLET:

- 4" CAST-A-SEAL BOOT OR EQUAL
- GASKET, CAST-A-SEAL BOOT OR EQUAL

INLET AND OUTLET BAFFLE AND FILTER:

- WISCONSIN, SEE DETAIL #10
- (OTHER STATES SEE CHART)

LIQUID CAPACITY: 26.81 GAL/IN

HOLDING TANK:

- OUTLET HOLE PLUGGED
- ACTUAL CAPACITY: 1,286 GALLONS

LOADING DESIGN: 8' 0" UNSATURATED SOIL

MN TANKS:

- WILL HAVE ONE VENT OVER OUTLET
- AND WILL HAVE TWO VENTS IN COVER OVER INLET

TANK CAN BE USED AS:

- SEPTIC/ HOLDING/ PUMP OR SIPHON

CUSTOMIZED TANKS:

TANKS CAN BE CUSTOMIZED CONTACT WIESER CONCRETE

TANKS ARE MANUFACTURED TO MEET OR EXCEED ASTM C-1227 REQUIREMENTS

SCALE: 1/4" = 1'	REV NO.	DATE:	
DRAWN BY: SWT			
DATE: JANUARY 2008			
FILE: W1250-MR			
WIESER CONCRETE			
W3716 US HWY10, MAIDEN ROCK, WI 54750			
800-325-8456			
W1250-MR	SEPTIC MANUAL		
	REV. JAN. 2008		
SHEET NO.			
0 OF 0			