

W1300-MR TANK SPECIFICATIONS

DIMENSIONS:

WALL: 2 1/2"
 BOTTOM: NONE
 COVER: 4"
 MANHOLE: 24" I.D. PRECAST CONCRETE RISER
 HEIGHT: 72" O.D.
 OUTSIDE DIAMETER: 84" O.D.
 BELOW INLET: 55" O.D.

WEIGHT: 4,280 LBS.

INLET:

4" CAST-A-SEAL BOOT OR EQUAL
 GASKET, CAST-A-SEAL BOOT OR EQUAL

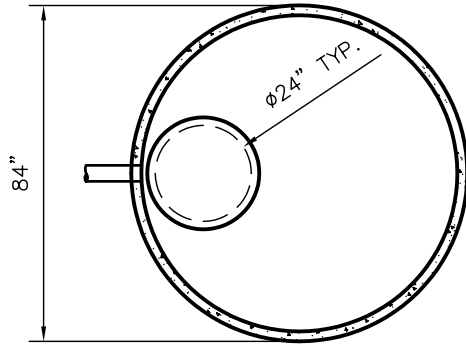

TOP VIEW

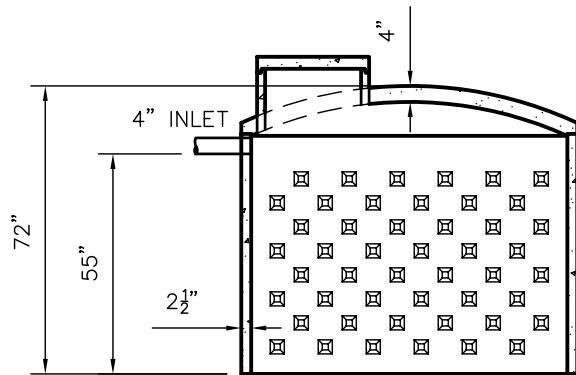

SIDE VIEW

LOADING DESIGN: 8' 0" UNSATURATED SOIL

TANK CAN BE USED AS:
 DRY WELL

CUSTOMIZED TANKS:
 TANKS CAN BE CUSTOMIZED CONTACT WIESER CONCRETE

TANKS ARE MANUFACTURED TO MEET OR EXCEED ASTM C-1227 REQUIREMENTS

SCALE: 1/4" = 1'	REV NO.	DATE:
DRAWN BY: SWT		
DATE: JANUARY 2008		
FILE: W1300-MR		
WIESER CONCRETE		
W3716 US HWY10. MAIDEN ROCK, WI 54750		
800-325-8456		
W1300-MR	SEPTIC MANUAL	
	REV. JAN. 2008	
SHEET NO.		
0 OF 0		