

W1250 750-MR TANK SPECIFICATIONS

DIMENSIONS:

WALL: 2 1/2"
 BOTTOM: 3"
 COVER: 6"
 MANHOLE: 24" I.D. PRECAST CONCRETE RISER
 HEIGHT: 66" O.D.
 LENGTH: 155" O.D.
 WIDTH: 86" O.D.
 BELOW INLET: 53" O.D.
 LIQUID LEVEL: 48"
 WEIGHT: 14,860 LBS. SEPTIC

INLET AND OUTLET:

4" CAST-A-SEAL BOOT OR EQUAL
 GASKET, CAST-A-SEAL BOOT OR EQUAL

INLET AND OUTLET BAFFLE AND FILTER:

WISCONSIN, SEE DETAIL #10
 (OTHER STATES SEE CHART)

LIQUID CAPACITY: 27.66 GAL/IN (SEPTIC)
 16.12 GAL/IN (PUMP)

LOADING DESIGN: 8' 0" UNSATURATED SOIL

MN TANKS:

WILL HAVE ONE VENT OVER OUTLET
 AND WILL HAVE TWO VENTS IN COVER OVER INLET

TANK CAN BE USED AS:

SEPTIC/ HOLDING/ PUMP OR SIPHON
 OR SEPTIC/SIPHON

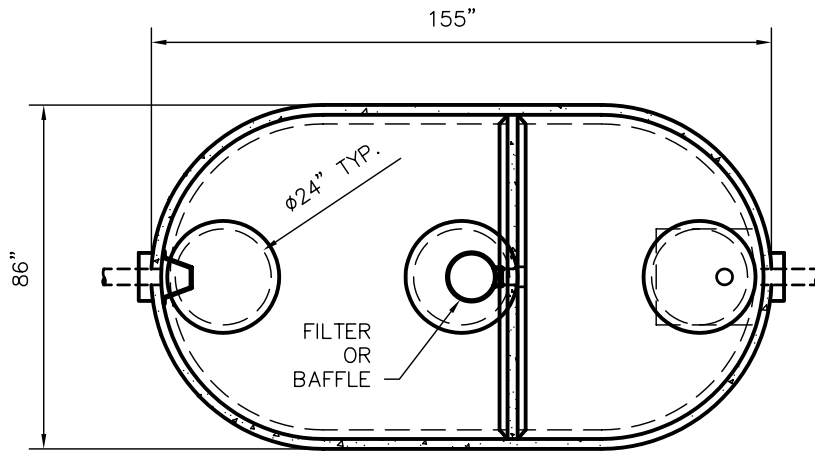

TOP VIEW

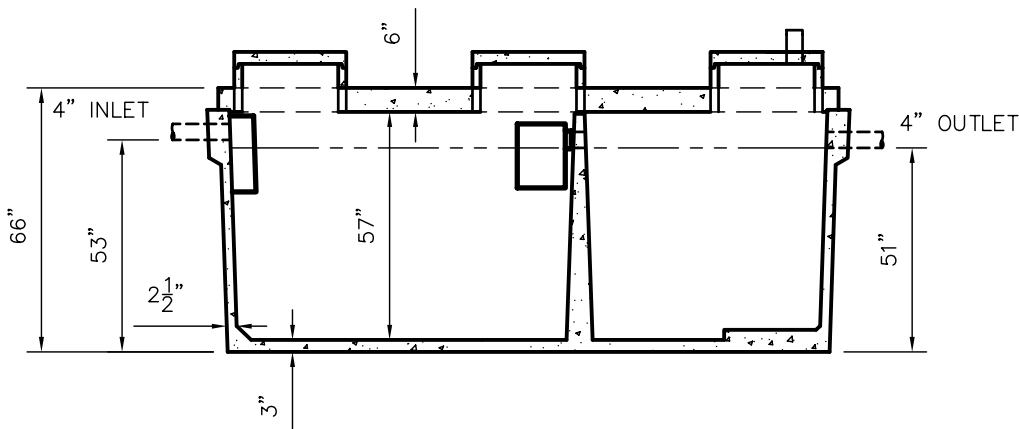

SIDE VIEW

CUSTOMIZED TANKS:

TANKS CAN BE CUSTOMIZED CONTACT WIESER CONCRETE

TANKS ARE MANUFACTURED TO MEET OR EXCEED ASTM C-1227 REQUIREMENTS

DATE:

REV NO.

SCALE: 1/4" = 1'

DRAWN BY: SWT

DATE: JANUARY 2008

FILE: W1250 750-MR

WIESER CONCRETE

W3716 US HWY10. MAIDEN ROCK, WI 54750

800-325-8456

W1250 750-MR

SEPTIC MANUAL

REV. JAN. 2008

SHEET NO.

0 OF 0