

WLP2000-FDL TANK SPECIFICATIONS

DIMENSIONS:

WALL: 3"
 BOTTOM: SEPTIC 3"
 HOLDING 5" (ADD 2,600 LBS.)
 COVER: 5"
 MANHOLE: 24" I.D. PRECAST CONCRETE RISER
 HEIGHT: 54 1/2" O.D.
 LENGTH: 175" O.D.
 WIDTH: 84" O.D.
 BELOW INLET: 43" O.D.
 LIQUID LEVEL: 38"
 WEIGHT: 17,070 LBS.

INLET AND OUTLET:
 4" CAST-A-SEAL BOOT OR EQUAL
 GASKET, CAST-A-SEAL BOOT OR EQUAL
INLET AND OUTLET BAFFLE AND FILTER:
 WISCONSIN, SEE DETAIL #10

LIQUID CAPACITY: 56.63 GAL/IN

LOADING DESIGN: 8' 0" UNSATURATED SOIL

HOLDING TANK:
 OUTLET HOLE PLUGGED
 ACTUAL CAPACITY: 2,105 GALLONS

TANK CAN BE USED AS:
 SEPTIC/ HOLDING/ PUMP OR SIPHON

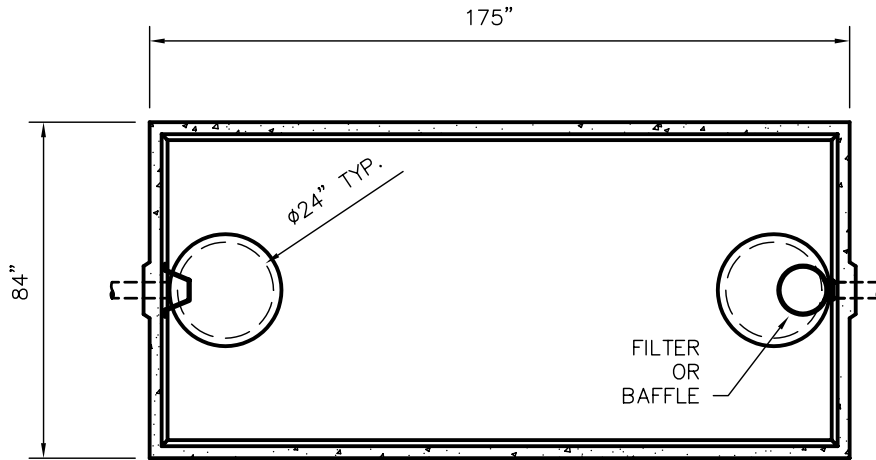

TOP VIEW

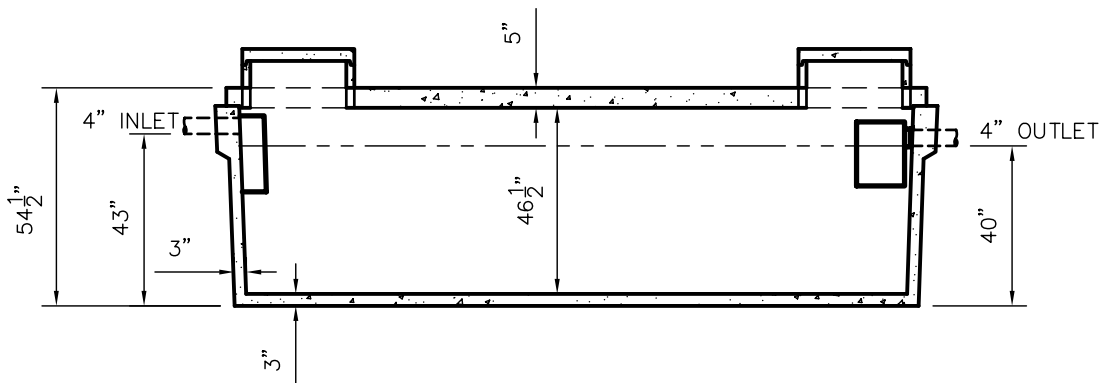

SIDE VIEW

CUSTOMIZED TANKS:
 TANKS CAN BE CUSTOMIZED CONTACT WIESER CONCRETE
 TANKS ARE MANUFACTURED TO MEET OR EXCEED ASTM C-1227 REQUIREMENTS

SCALE: 1/4" = 1'	REV NO.	DATE:	
DRAWN BY: SWT			
DATE: JANUARY 2008			
FILE: WLP2000-FDL			
WIESER CONCRETE			
W3716 US HWY10. MAIDEN ROCK, WI 54750			
800-325-8456			
WLP2000-FDL	SEPTIC MANUAL		
	REV. JAN. 2008		
SHEET NO.	OF		
0	0		