

WLP1000 500-FDL TANK SPECIFICATIONS

DIMENSIONS:
 WALL: 3"
 BOTTOM: 3"
 COVER: 5"
 MANHOLE: 24" I.D. PRECAST CONCRETE RISER
 HEIGHT: 53 1/2" O.D.
 LENGTH: 149" O.D.
 WIDTH: 78" O.D.
 BELOW INLET: 42" O.D.
 LIQUID LEVEL: 37"
 WEIGHT: 15,000 LBS.

INLET AND OUTLET:
 4" CAST-A-SEAL BOOT OR EQUAL
 GASKET, CAST-A-SEAL BOOT OR EQUAL
 INLET AND OUTLET BAFFLE AND FILTER:
 WISCONSIN, SEE DETAIL #10

LIQUID CAPACITY: 27.18 GAL/IN (SEPTIC)
 13.67 GAL/IN (PUMP)

LOADING DESIGN: 8' 0" UNSATURATED SOIL

TANK CAN BE USED AS:
 SEPTIC/SEPTIC, SEPTIC/PUMP
 OR SEPTIC/SIPHON

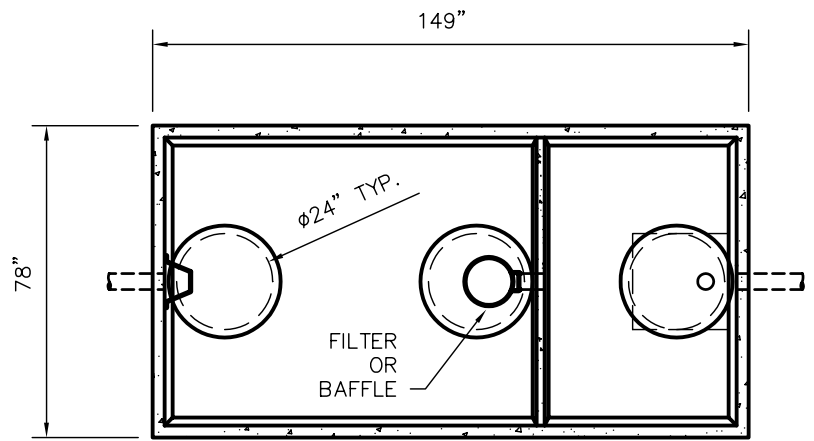

TOP VIEW

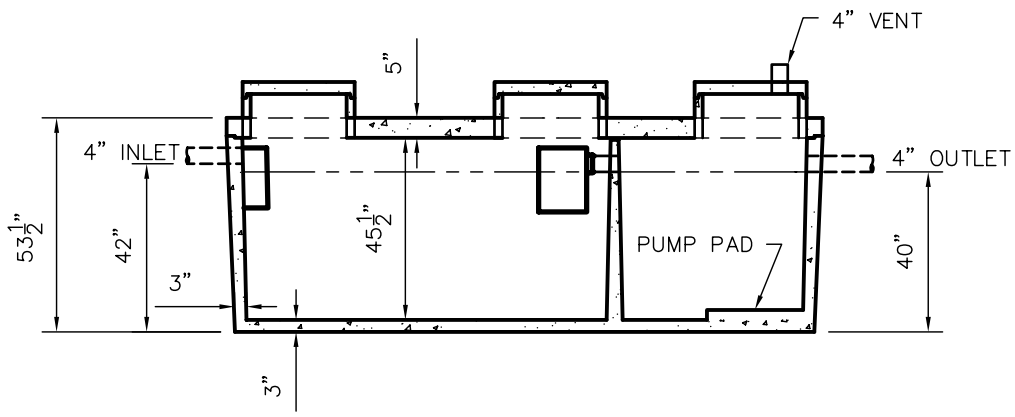

SIDE VIEW

CUSTOMIZED TANKS:
 TANKS CAN BE CUSTOMIZED CONTACT WIESER CONCRETE
 TANKS ARE MANUFACTURED TO MEET OR EXCEED ASTM C-1227 REQUIREMENTS

SCALE: 1/4" = 1'	REV NO.	DATE:
DRAWN BY: SWT		
DATE: JANUARY 2008		
FILE: WLP1000 500-FDL		
WIESER CONCRETE		
W3716 US HWY10. MAIDEN ROCK, WI 54750		
800-325-8456		
WLP1000 500-FDL	SEPTIC MANUAL	
	REV. JAN. 2008	
SHEET NO.	0 OF 0	