

# W1500 1000-FDL TANK SPECIFICATIONS

DIMENSIONS:  
 WALL: 3"  
 BOTTOM: 3"  
 COVER: 5"  
 MANHOLE: 24" I.D. PRECAST CONCRETE RISER  
 HEIGHT: 70" O.D.  
 LENGTH: 166" O.D.  
 WIDTH: 81" O.D.  
 BELOW INLET: 58" O.D.  
 LIQUID LEVEL: 53"  
 WEIGHT: 18,500 LBS.

INLET AND OUTLET:  
 4" CAST-A-SEAL BOOT OR EQUAL  
 GASKET, CAST-A-SEAL BOOT OR EQUAL  
 INLET AND OUTLET BAFFLE AND FILTER:  
 WISCONSIN, SEE DETAIL #10

LIQUID CAPACITY: 28.95 GAL/IN (SEPTIC)  
 19.54 GAL/IN (PUMP)

LOADING DESIGN: 8' 0" UNSATURATED SOIL

TANK CAN BE USED AS:  
 SEPTIC/SEPTIC, SEPTIC/PUMP  
 OR SEPTIC/SIPHON

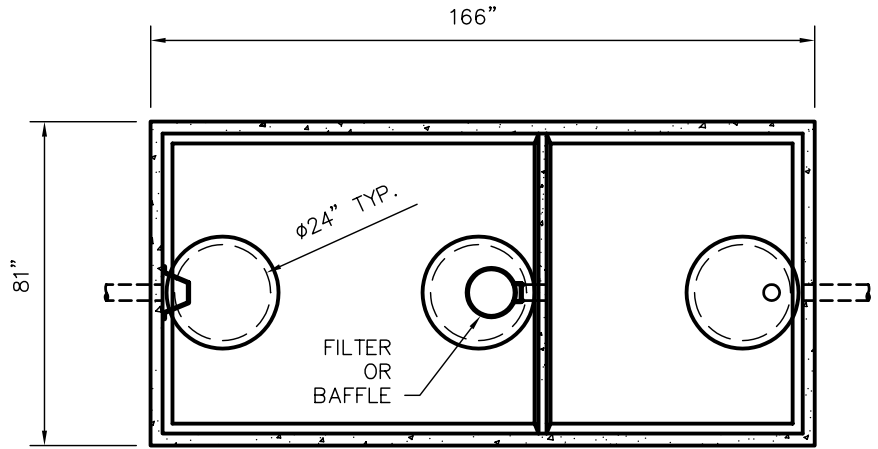

TOP VIEW

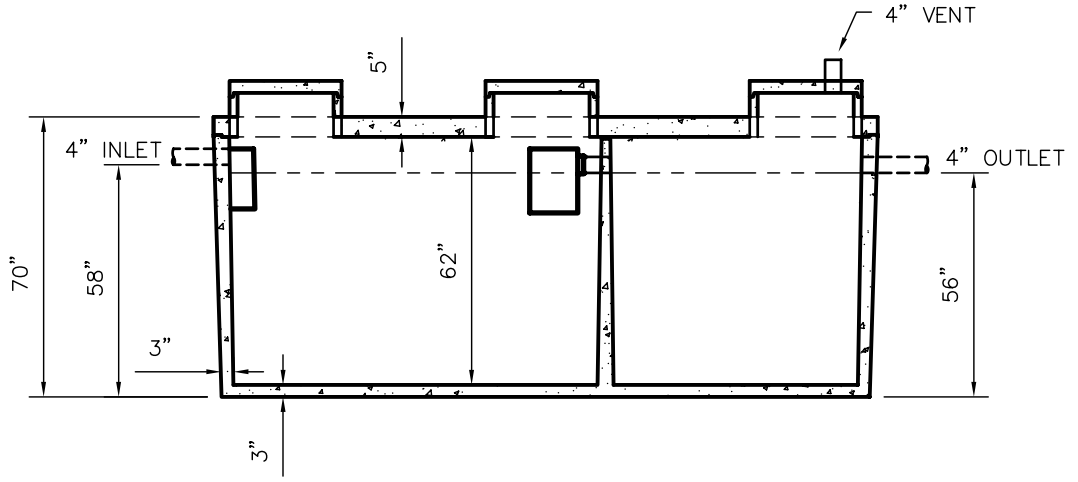

SIDE VIEW

CUSTOMIZED TANKS:  
 TANKS CAN BE CUSTOMIZED CONTACT WIESER CONCRETE  
 TANKS ARE MANUFACTURED TO MEET OR EXCEED ASTM C-1227 REQUIREMENTS

SCALE: 1/4" = 1'	REV NO.	DATE:
DRAWN BY: SWT		
DATE: JANUARY 2008		
FILE: W1500 1000-FDL		
<b>WIESER CONCRETE</b>		
W3716 US HWY10, MAIDEN ROCK, WI 54750		
800-325-8456		
W1500 1000-FDL	SEPTIC MANUAL	
	REV. JAN. 2008	
SHEET NO.	0 OF 0	